

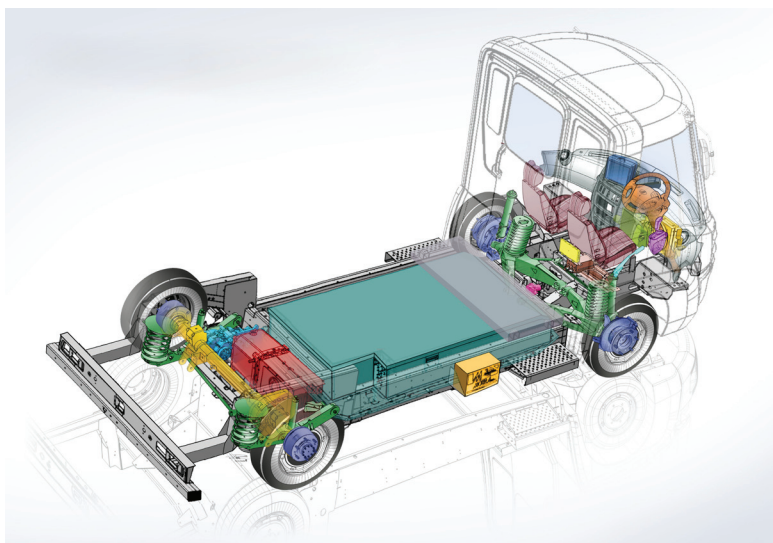

## Liberty Electric Cars, creator of leading edge electric vehicle technologies

Liberty Electric Cars designs, develops and produces leading edge electric vehicle technologies and vehicles to serve growing demand for zero-emission transport solutions in markets around the world. It then goes on to take care of these vehicles once sold through a team of highly trained and experienced EV professionals.

Our experienced and highly skilled engineers have invented, IP-protected innovative electric vehicle (EV) drive train technologies that can be employed in a wide variety of vehicle platforms like trucks, buses, 4x4, SUV, MPV, pick up trucks. Liberty Electric Cars has recently reinforced its engineering team and now has one of the most experienced teams in EV technology in the world. This unique team of engineers have created EVs that have driven over 2,500,000 miles - the greatest distance and thus best experience of any electric vehicle team in the world.



The company's development activity, Liberty E-Tech, designs and engineers EV technologies and complete vehicles for large vehicle platforms.

It is early as in the design study phase that our team integrates driving range, safety, comfort and costs to be able to arrive at the optimum result for our clients. Our priority is to make sure that all components installed as well as the entire drive train satisfies all the requirements on safety, homologation and EMC.

We have in depth expertise in the following areas: HV power systems, BMS, traction control, body systems, remote diagnostics and electronic architecture as well as unique energy storage systems.

In addition, Liberty Electric Cars has created a support and maintenance facility, Liberty E-Care to provide a high level of after sales service to EV customers globally.

Liberty Electric Cars has demonstrated its technical superiority in EV platform technology with the launch of its flagship product, the Liberty E-Range. This is the world's first pure electric, luxury 4x4 that has a range of 200 miles on a single charge – this is the upper end of the range that any current EV is able to achieve.

Liberty's achievements in the field of EV drive train development, service and support has led to a number of contracts with global OEM's who have recognized the companies leadership position in this exciting and fast developing sector.



## Liberty Electric Cars

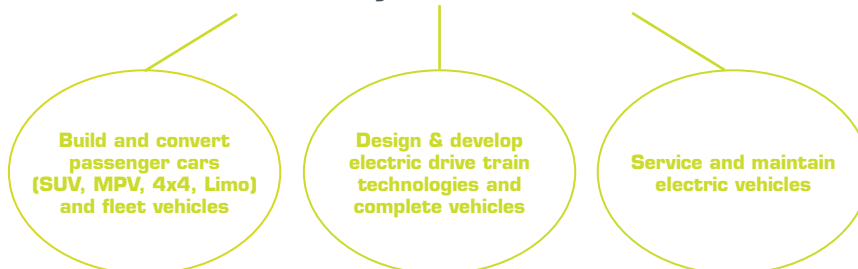

Contact: Barry Shrier [barry@liberty-ecars.com](mailto:barry@liberty-ecars.com) • [www.liberty-ecars.com](http://www.liberty-ecars.com)



## Liberty E-Care

### Pioneering in after sales support for Electric Vehicles

As more and more Electric Vehicles populate our roads, this will create a demand for service and support from properly trained, highly skilled engineers equipped with new and unique diagnostic tools; experience in safe intervention for high voltage systems and access to the right parts to affect quality repairs.

Liberty E-Care has been created to meet such a demand, and to be able to provide independent, qualified advice to third parties with an interest in this emerging sector of the automotive industry (Leasing and Rental companies, finance houses etc.). **The Liberty**

**E-Care team can provide a host of background information on the impact of charging types and cycles on battery life; the effect of temperature on vehicle performance; cost of replacement parts; likely failure issues; repair costs and times, conversion programmes, and residual vehicle values.**

The Liberty E-Care team was created from the merger of the Liberty Electric Car support team and the Modec Service operation, which collectively had over 250 electric vehicles in the market across Europe. The combined team has **over 200 man years of experience in automotive engineering, and 70 man years specifically in the EV sector.** This unmatched level of knowledge and experience equips the team to supply the very highest level of service and support for all types of Electric Vehicles.

The Liberty E-Care team is supported by the Liberty E-Tech team, probably the worlds leading Electric Vehicle



drive train development business, which provides in depth support, analysis and testing when required.

Liberty E-Care has recently launched a **membership support programme called "The Club"**. For an annual membership fee, the owner of an electric vehicle can access our highly skilled operators via a telephone hotline, receive software updates as and when required, and, in the case of an intervention, avoid paying a call out fee. The Liberty E-Care team is field based and thus intervention takes place at the owner's location reducing down time.

For more information, please contact Graham Gould • [graham.gould@liberty-ecars.com](mailto:graham.gould@liberty-ecars.com) • T: +442476408265

